



EMC tergoUV™-Cabinet

Clean. Charge. Secure.

The EMC tergoUV™-Cabinet prevents the spread of pathogens like COVID-19 on devices, equipment and hard and soft goods. Ideal for items that are routinely handled in public and work settings, the tergoUV-Cabinet uses UV-C light to disinfect up to 99.9% of germs and viruses in 45 seconds, including COVID-19. Simply place or hang the item in the cabinet, push a button and disinfect. Immediately return to use, or customize to recharge devices so they are ready when needed.



Powerful Disinfectant

Disinfect bacteria, viruses and other pathogens, including COVID-19 and influenza, with a 99.9% effectiveness rate.



Fast...Really fast

Complete a disinfection cycle in 45 seconds.



Consistent

Deliver uniform and scientifically proven disinfection with the push of a button.



Charge + Secure Option

After disinfecting, recharge and securely store high touch electronics so they are ready for next use.



Made in the USA

EMC's tergoUV-Cabinet is manufactured in the USA.



EPA Registered

Registered with the EPA as providers of disinfecting solutions. The cabinet is also deemed environmentally safe in all states.



Electronic Display

A touch screen automates on/off for the magnetic locking safety system and provides valuable analytics and customization.



Mobile

Equipped with heavy duty casters, it can be easily moved where needed most or to storage when not in use.



Flexible

Disinfects a variety of items including textiles, shoes, small electronics, key cards and other high touch merchandise.



Stop the Spread of Human Pathogens

The exterior panels of the tergoUV-Cabinet can be painted or personalized to match your brand and provide the right feel for your dressing room environments.

Secure Disinfection

- Designed for chemical-free, non-contact disinfection
- Safe and simple to operate
- Heavy-duty stainless steel cabinet

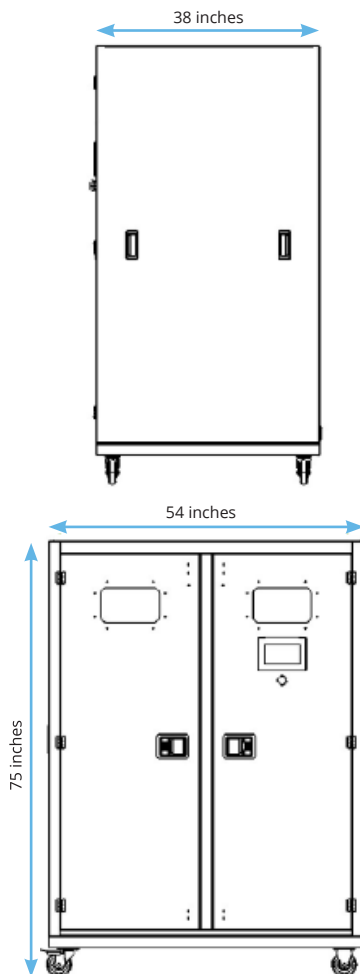

Specifications

- Internal dimensions: 52" L x 36" W x 67" H
- Outside dimensions with castors: 54" L x 38" W x 75" H
- Weight: approx. 680 pounds
- Input voltage: 120 VAC
- UV-C Output: 36 watts per lamp X 10 lamps
- UV-C Dosage: 40mj/cm² at 254 nm UV-C light (standard 45 second cycle)

Features

Standard

- Redundant safety systems
 - Defaults to locked when not in use
 - Automatic power off when doors open
 - Emergency stop
 - Magnetic door lock (optional)
- Cycle counter
- Low kWh consumption: 0.4 kWh per day depending upon usage
- Casters for mobility

Custom

- LCD touchscreen
- Automated controls, including cycle times and maintenance indicators
- Customizable interior can include racks and shelving
- Personalized exterior panels can be painted or identified to match your brand

Maintenance

Routine Upkeep

- Dusting lamps
- Vacuuming inside

Service Plan

- Lamp replacement (quarterly or semi-annually depending on usage)
- Ballast replacement (every 2-3 years)
- Estimates available

ETL certification pending

For more information or to learn how the tergoUV-Cabinet can help you disinfect goods quickly, contact us today.